



HOW TO DAISY CHAIN FRONIUS SNAPINVERTERS IN A FRONIUS SOLAR NET COMMUNICATION LOOP

**FOR FRONIUS GALVO, FRONIUS PRIMO,
FRONIUS SYMO & FRONIUS ECO**

Quick Guide

© Fronius International GmbH
Version 1. 0 / 02/2019
Fronius Solar Energy

Fronius reserves all rights, in particular rights of reproduction, distribution and translation.
No part of this work may be reproduced in any way without the written consent of Fronius. It must not be saved, edited, reproduced or distributed using any electrical or electronic system.
You are hereby reminded that the information published in this document, despite exercising the greatest of care in its preparation, is subject to change and that neither the author nor Fronius can accept any legal liability.
Gender-specific wording refers equally to female and male form.

TABLE OF CONTENTS

1	SCOPE OF USE	4
2	NETWORKING FRONIUS INVERTERS IN A COMMUNICATION LOOP	4
3	CABLE REQUIREMENTS	6
4	SETTING THE INVERTER ADDRESS	7

1 SCOPE OF USE

When installing multiple inverters on the same site, it is possible to daisy chain Fronius inverters with each other.

To do this it is necessary to connect a Master-Inverter with up to 99 Slave-Inverters.

- Master Inverter = Fronius SnapINverter + Fronius Datamanager 2.0 (example Fronius Symo 10.0-3-M)
- Slave Inverter = Fronius SnapINverter (example Fronius Symo 10.0-3-M light)

In case there are multiple Master inverters installed, it is possible via the “Master/Slave” switch on the Datamanager to transform a Master inverter into a Slave unit.

2 NETWORKING FRONIUS INVERTERS IN A COMMUNICATION LOOP

When linking multiple inverters, each inverter must be connected in a communication loop using a TIA/EIA-568B compliant Ethernet cable.

SnapINverters come equipped with 2 RJ45 sockets labelled IN and OUT. The Ethernet cable connection should always run from the OUT socket on one inverter, to the IN socket on the next inverter.

RJ45 termination plugs supplied with the inverter must then be installed in the empty **Solar Net IN** and **OUT** connection sockets at the start and end of the daisy chain.

Up to 99 slave inverters can be connected to a master inverter. To maximise communication speed, communication loops should be kept as short as possible.

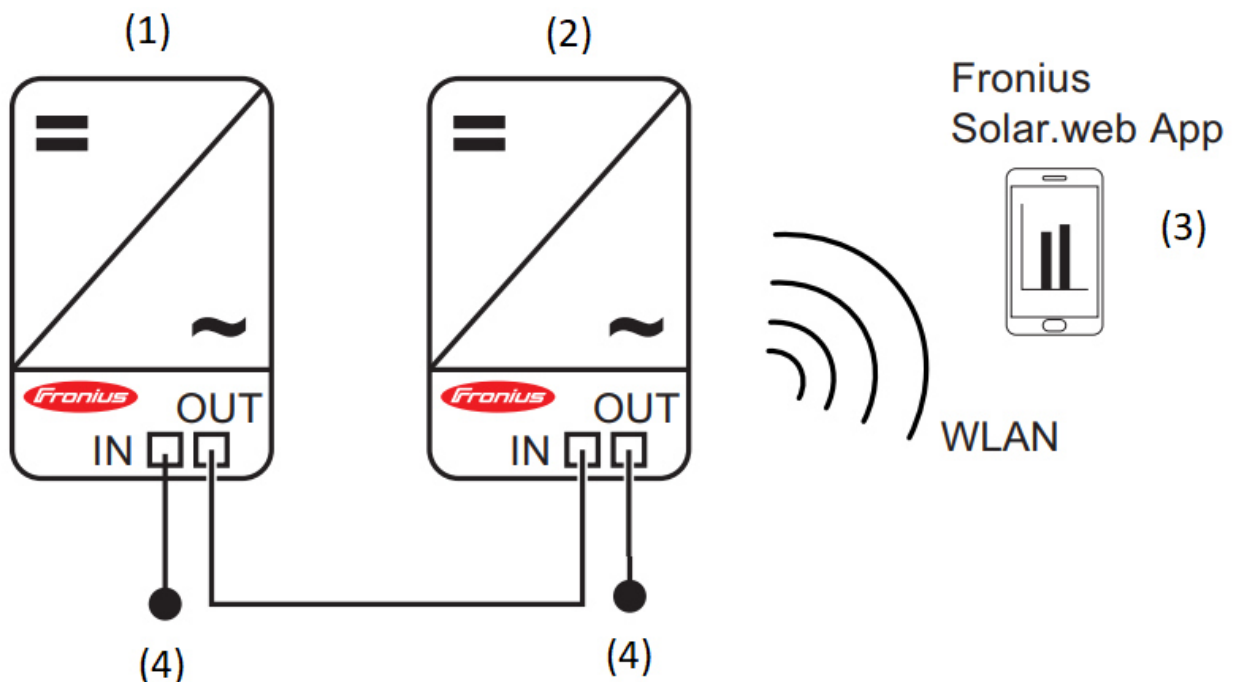

- (1) SnapINverter (Galvo, Primo, Symo, Eco) with Fronius Datamanager
- (2) SnapINverter (Galvo, Primo, Symo, Eco) without Fronius Datamanager
- (3) Smart Phone with Fronius Solar.web App
- (4) Terminal Plug

IMPORTANT! To maintain the IP protection class of the inverters, be careful to maintain a tight seal at the communication cable inlet.

- / Only remove blanking plugs required for the number and cross-section of the data communication cables being used.
- / Before screwing the sealing cap over the cable inlet, double check that all openings are closed with blanking plugs and that the sealing plug is fitted correctly.

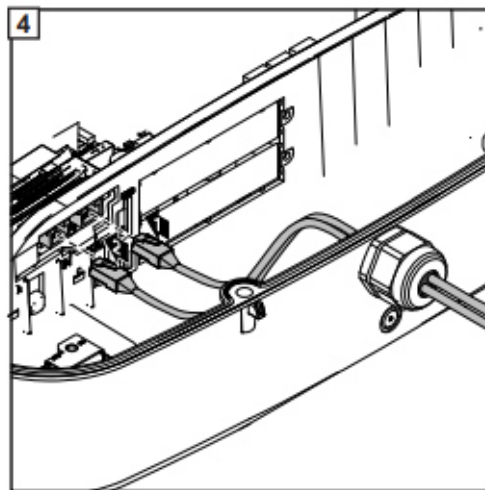
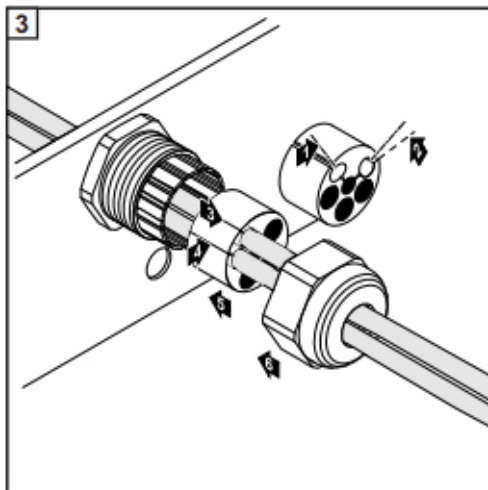
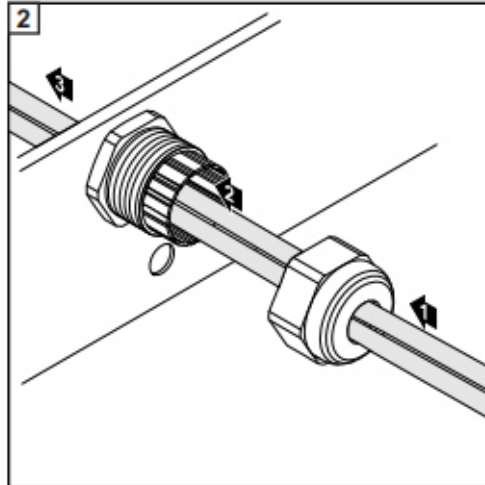
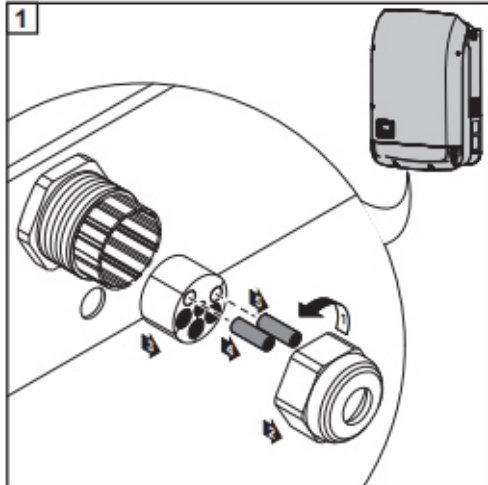

3 CABLE REQUIREMENTS

The data connection for the Fronius Solar Net client is a 1:1 connection using 8-pin data cables and RJ-45 plugs. The overall line length in a Fronius Solar Net ring must not exceed 1,000 mts.

Shielded CAT5 (new) and CAT5e (old) cables compliant with ISO 11801 and EN 50173 must be used for the Fronius Solar Net client cabling. Other cables are not permitted.









IMPORTANT! Do not use ISO/IEC-11801 U/UTP cables!

Allowed cable types:

- S/STP -F/FTP -F/UTP
- F/STP -SF/FTP -U/FTP
- S/FTP -S/UTP -U/STP

The shield must be crimped onto a CAT5-compatible shielded plug. Make sure that the shield is only grounded on one side of the cable!

Due to the fact that the wires in Ethernet cables are twisted, you must make sure the twisted pairs of wires are assigned correctly for cabling in accordance with TIA/EIA-568B:

Fronius Solar Net contact	Pair no.	Color
1 +12 V	3	 white/orange line
2 GND	3	 orange/white line or orange
3 TX+ IN, RX+ OUT	2	 white/green line
4 RX+ IN, TX+ OUT	1	 blue/white line or blue
5 RX- IN, TX- OUT	1	 white/blue line
6 TX- IN, RX- OUT	2	 green/white line or green
7 GND	4	 white/brown line
8 +12 V	4	 brown/white line or brown

Cabling compliant with TIA/EIA-568B

4 SETTING THE INVERTER ADDRESS

To enable communication between inverters, it is necessary to assign each inverter in a communication loop a unique address (inverter number).

To assign the unique number, please follow the steps below:

Enter the **Setup Menu** on the inverter display



Choose **DATCOM** in the Setup Menu

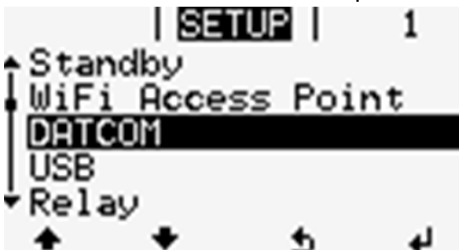

Choose **Inverter Number** in the DATCOM Menu



Number each inverter in **sequential order**

